

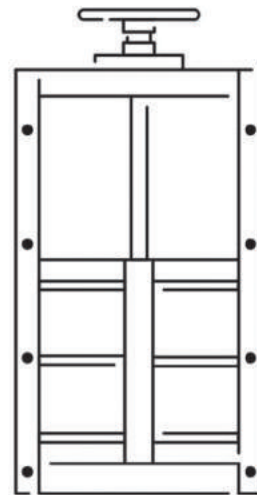

# LECOTECH PENSTOCK CATALOGUE



*Dedicated to your solutions.*



A dynamic water splash in shades of blue, with droplets and ripples, serves as the background for the page. The water is captured in mid-air, creating a sense of movement and freshness. The colors range from light, airy blues to deeper, more saturated tones, especially in the shadows of the splash.

# CONTENTS

---

1.0 LECOTECH Penstock Type	2-3
2.0 LECOTECH Penstock Design Feature	4-8
3.0 Standard Materials of Construction	10-12
4.0 LECOTECH Penstock Accessories	13-16

---



# 1.0 LECOTECH PENSTOCK TYPE



Weir Gate/Downward  
Opening Penstock  
(WG)



Channel Mounted  
Penstock  
(CM)



Wall Mounted  
Penstock  
(WM)

## Wall 1.1 Mounted Penstock (WM)

**LECOTECH** wall mounted penstock (WM) is the popular and common of penstock used in wide variety of water and waste water work application as water / sewage treatment project and flood control project.

**LECOTECH** Penstock has provides penstock which fabricating with stainless steel under BS 7775 or AWWA C561 specification. This type of penstock can be used in on seating and off seating water pressure direction with rising or non-rising stem option.

**LECOTECH** offer sizes 150 mm x 150 mm to 1200 mm x 1200 mm, the WM model has a unique self-adjusting seal design that can achieve minimal equal seating and unseating (bidirectional) leakage rates. Sizes 1300 mm x 1300 mm up to 4000 mm x 4000 mm are also available in bidirectional configurations. The maximum leakage rate is lower than the maximum allowable recommended by BS7775 standard under normal conditions.



## 1.2 Channel Mounted Penstock (CM)



**LECOTECH** Channel mounted gate (CM) is designed for open channel installation with a highly versatile flow control in waste water treatment plants, irrigation, hydraulic works and hydro-electric power plants. It is used for channel water flow direction or water distribution control purpose and allows to overflow on top of the gate. Technically the water head design for channel penstock shall follow the height of the gate. However, higher water head can be designed upon request.

The sealing system is incorporated on both laterals and bottom area of the slide, resulting in a perfect seal without the need of wedges on the gate. From sizes 150 mm x 150 mm to 2000 mm x 2000 mm, the CM Penstock has a unique seal design for applications requiring accurate flow regulation and optimum performance. The maximum leakage rate is lower the maximum allowable recommended by BS7775 standard under normal conditions. CM Penstock can use in on and off seating with rising and non-rising stem optional. All the sealing surface and the assembly hardware is used corrosion resistant material.

**LECOTECH** Channel Mounted CM Penstock is available in 4 sides seating face and the allowable leakage rate fulfill to the BS7775 standard.

## Weir Gate | Downward Opening Penstock (WG) 1.3



**LECOTECH** Weir Gate (WG) is designed for downward opening applications where a more accurate flow control is required. It also can be used in water distribution, drainage and other places for flow and level controlling. The water flows over the top of the slide permitting a constant upstream water elevation.

**LECOTECH** Weir Gate (WG) is available from sizes 150mm x 150mm up to 2000mm x 2000mm.

The sealing system is incorporated on 3 sides (both laterals and bottom), resulting in a substantially watertight seal without the need of wedges on the gate. This unique design achieves bidirectional performance (seating and unseating pressure conditions). Additionally, a 4 sides sealing system to BS7775 standard is available upon request.



# 2.0 LECOTECH Penstock Design Feature



Modular Design



Frame Configuration Options



Mounting Configuration Options



Flush Bottom Design



Modular Configuration For Actuation



HMWPE Guide

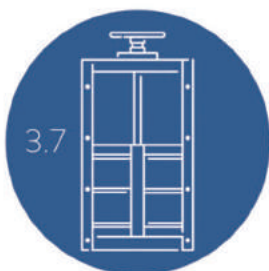

Sealing Design



Spindle & Stem Nut



Leakage Allowance



Seating

## 2.1 Modular Design

- Allows for both Open Yoke Frame and Self-Contained /Closed Yoke Frame configurations.
- Allows Rising or Non-Rising stem configurations



▲ Self-contained / Closed Yoke Frame



▲ Open Yoke Frame



### Non-Rising Stem Configuration 2.1.1

As standard, non-rising stem gate configurations are used with self-contained frame designs. Therefore, the stem extension does not support the axial load (only torque) and less wall brackets are required. As a general rule, a stem guide should be installed every 3 meters of unsupported stem extension.



### Rising Stem Configuration 2.1.2

As standard, rising stem gate configurations are used with open-frame designs. Therefore, the stem extension has to support the axial load when the gate is operated to avoid any buckling failure. As a general rule, a stem guide should be installed every 2 meters of unsupported stem extension.

## 2.2 Frame Configuration Options

- Square (standard)
- Round & Rectangular opening
- Round base

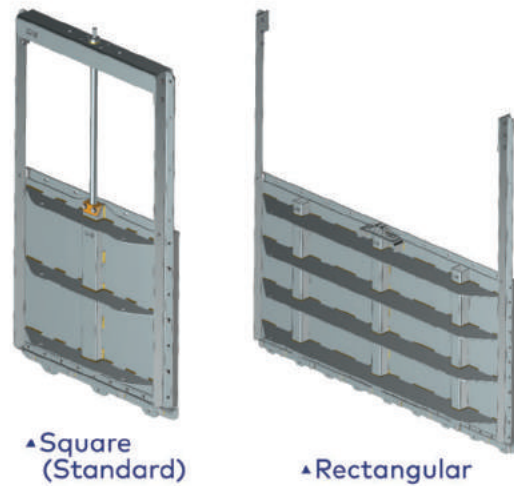

## Mounting Configuration 2.3 Options

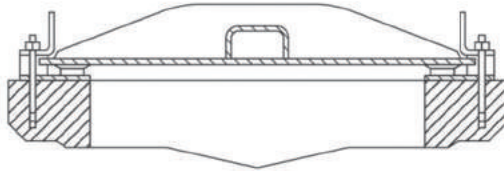

- Wall Mount (standard for sizes  $\leq 1200$ )

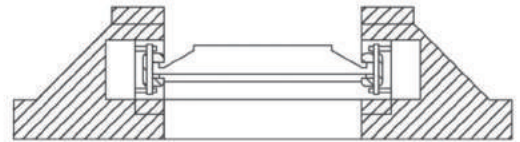

- Embedded in concrete (standard for bidirectional and sizes  $>1200$ )

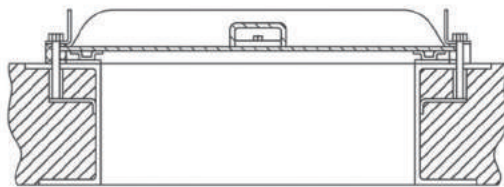

- Thimble Mount

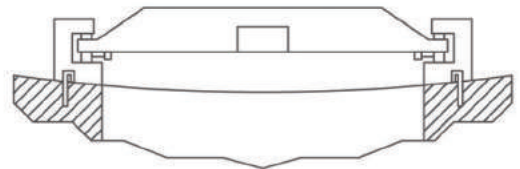

- Curved Wall Mount

## 2.4 Flush Bottom Design

To prevent the rubbish stay or block at the slot between the bottom of the penstock and the mounted wall. This is used for preventing the gate operation stuck and water leakage cause by the stuck at the bottom gapping.

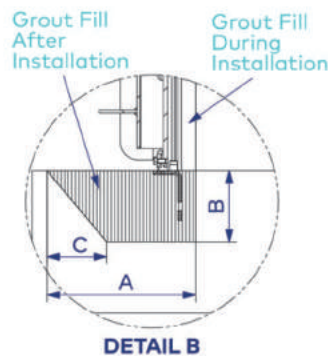

Stainless Steel Penstock			
PENSTOCK SIZE	A	B	C
200 - 500	200	100	50
600 - 900	250	150	70
1000 - 1400	300	200	90
1500 - 2000	400	230	100

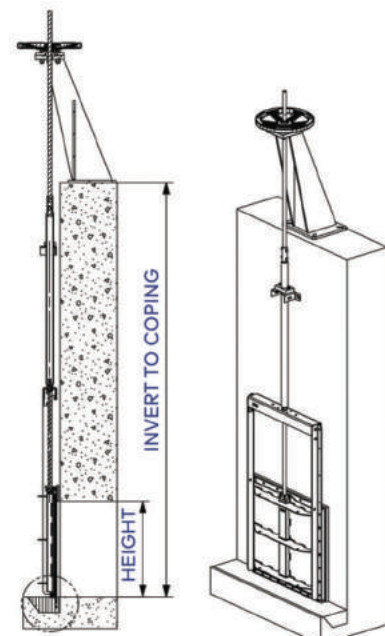



## 2.5 Modular Configuration for Actuation

Suitable for actuation with manual, electric, pneumatic or hydraulic actuators

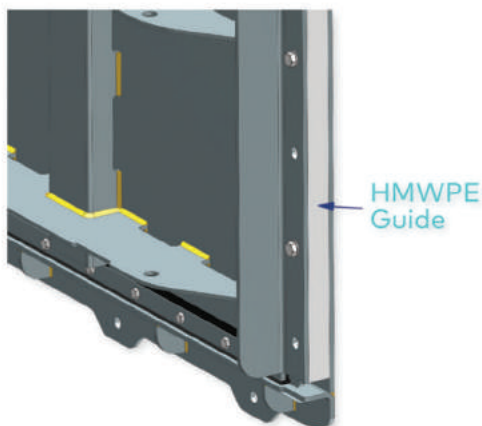
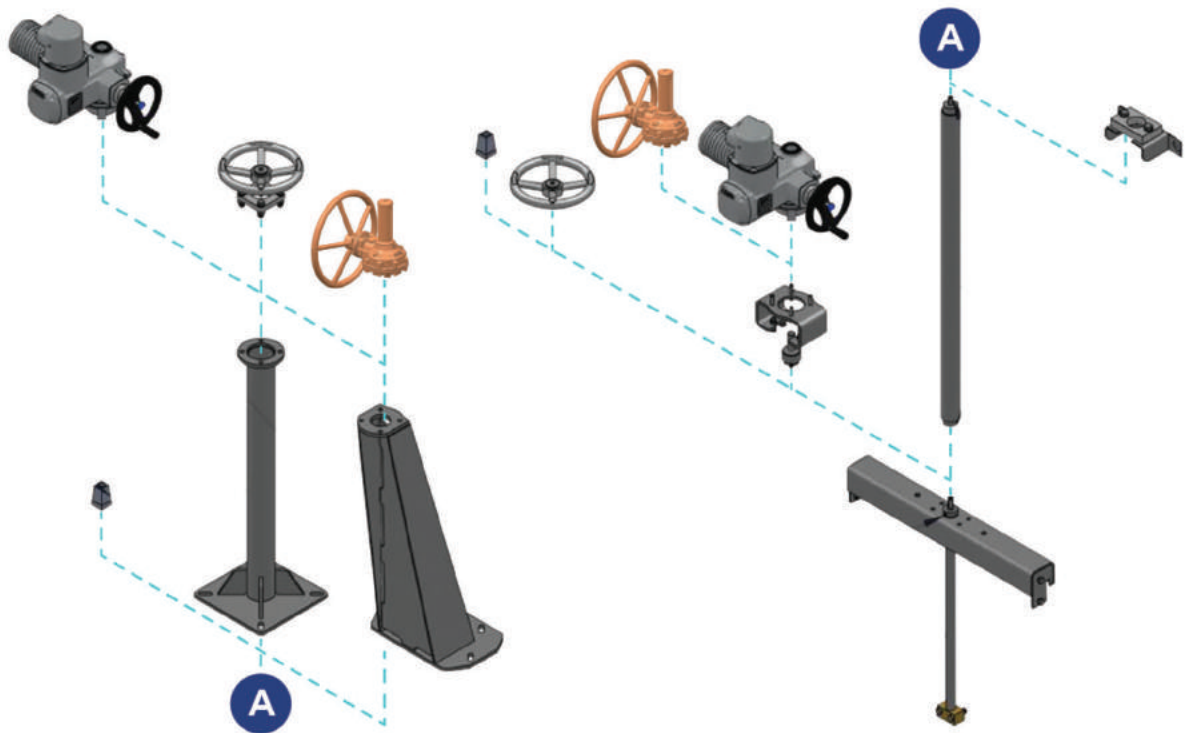

## HMWPE Guide 2.6

- Self-cleaning HMWPE guides reduce the friction coefficient during operation, minimizing therefore the actuation thrust and extending the seal life.
- Machined slot for slide on guides to prevent "seesaw" effect when opening and closing the slide.

## 2.7 Sealing Design

- Seal design is self adjusting (wedge-less design), thus reducing torque requirements
- Slide ribs are designed to avoid crevice corrosion.
- Seal and guides bolting is completely separated from the frame anchoring

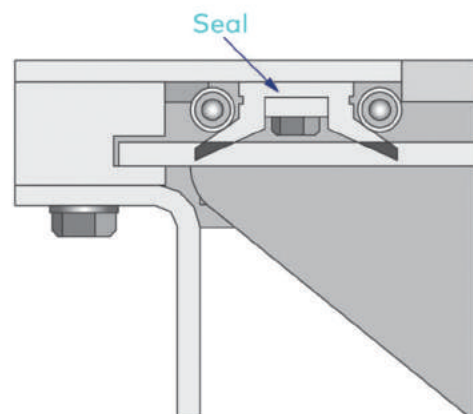



## 2.8 Spindle & Stem Nut

- Spindles are machined from stainless steel 304/ 316 according to DIN103 in trapezium thread as the optimum thread form for ease of operation, long life, and prevention of ragging. Both rising and non-rising options are available.
- Gunmetal is used as the spindle nut for better thrust movement

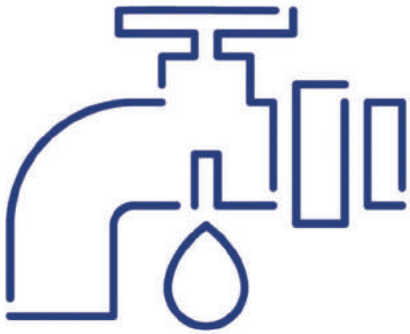
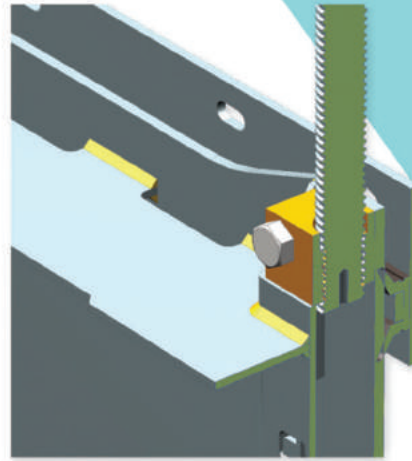

### EXAMPLE:

500mm (W) x 500mm (H) Penstock,

- Under 6 meters water head,  $0.5l \times 1\text{min} \times (0.5\text{m} + 0.5\text{m} + 0.5\text{m} + 0.5\text{m})$   
= 1liter/min

- Under 10 meters water head,  $(0.1 + 0.067 \times 10\text{mWH}) \times (0.5\text{m} + 0.5\text{m} + 0.5\text{m} + 0.5\text{m})$   
= 1.54liter/min

## Leakage Rate 2.9

The leakage rate on WM model is lower than the maximum allowable defined by different standards under normal conditions:

- DIN 19569-4 (Class 5): 1,20 l/min per meter
- AWWA C-561: 1.24 l/min per meter
- **BS 7775:**
  - water heads  $\leq 6$  meters the leakage rate shall not exceed 0.5liter/ (min.m) of seal perimeter.
  - Water heads  $> 6$  meters, the maximum leakage rate, R in liter/ (min.m) of seal perimeter, shall conform to

$$R = 0.1 + 0.067 H$$

where H is the On / Off seating head in meter.

## 2.10 Seating

### Seating / Unseating Design Head:

	Uni / Bidirectional	Water Head	
		On Seating head pressure	Off-seating head pressure
Standard Range 150x150 - 1200x1200	BI-DIRECTIONAL	150-100: 10 mWC	150-1000: 10 mWC
		1100-1200: 6 mWC	1100-1200: 6 mWC
1300 X 1300 - 4000 X 4000	BI-DIRECTIONAL	Designed according to the project specification. Typically 6m WC ofseating and unseating water head	

- **LECOTECH** penstocks are factory assembled and tested eliminating the need for site adjustment
- All gate fasteners are stainless steel.

## 3.0 STANDARD MATERIALS OF CONSTRUCTION

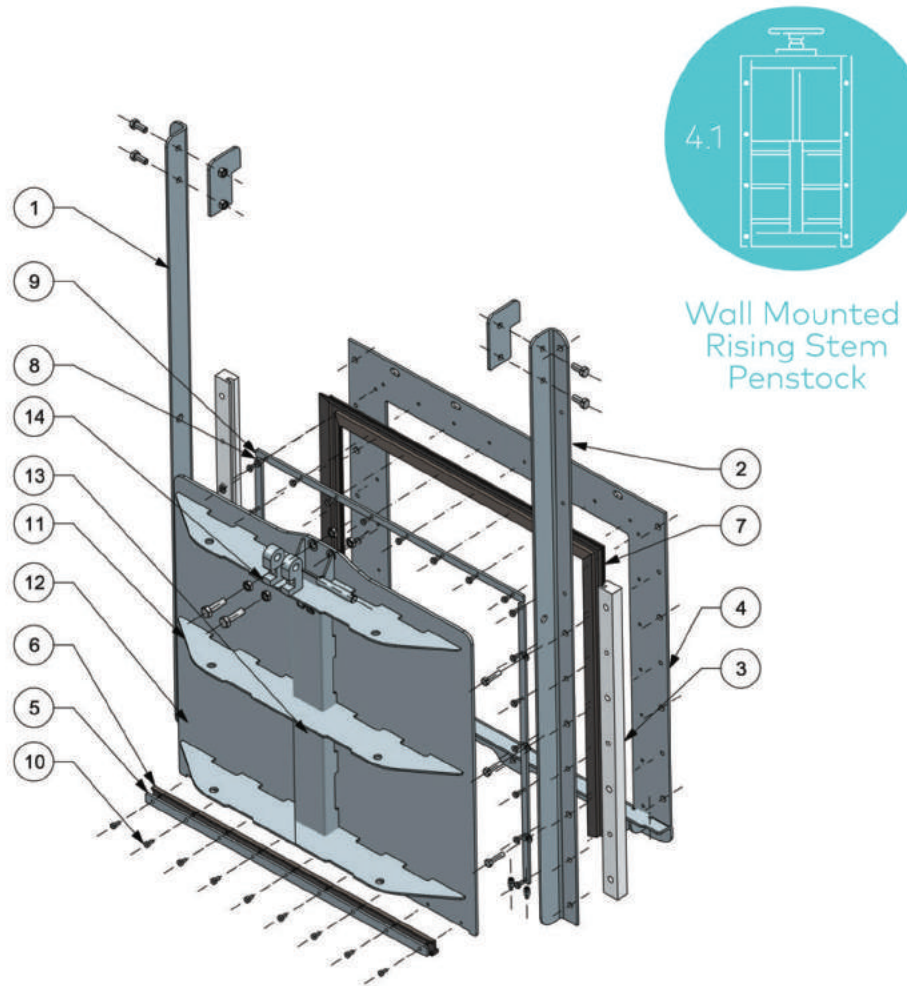

ITEM	DESCRIPTION	MATERIAL (STANDARD)
1	Left Frame Guide	Stainless Steel 304 or 316
2	Right Frame Guide	Stainless Steel 304 or 316
3	Side Slider	High Molecular Weight Polyethylene (HMWPE)
4	Body Frame	Stainless Steel 304 or 316
5	Bottom Retainer Plate	Stainless Steel 304 or 316
6	Bottom L Gasket	EPDM
7	Damper Gasket Joint	EPDM
8	Lateral Retainer Plate	Stainless Steel 304 or 316
9	Top Retainer Plate	Stainless Steel 304 or 316
10	Hex Bolt	Stainless Steel 304 or 316
11	Gate Horizontal Stiffener	Stainless Steel 304 or 316
12	Gate	Stainless Steel 304 or 316
13	Gate Vertical Stiffener	Stainless Steel 304 or 316
14	Gate Coupling Bracket	Stainless Steel 304 or 316



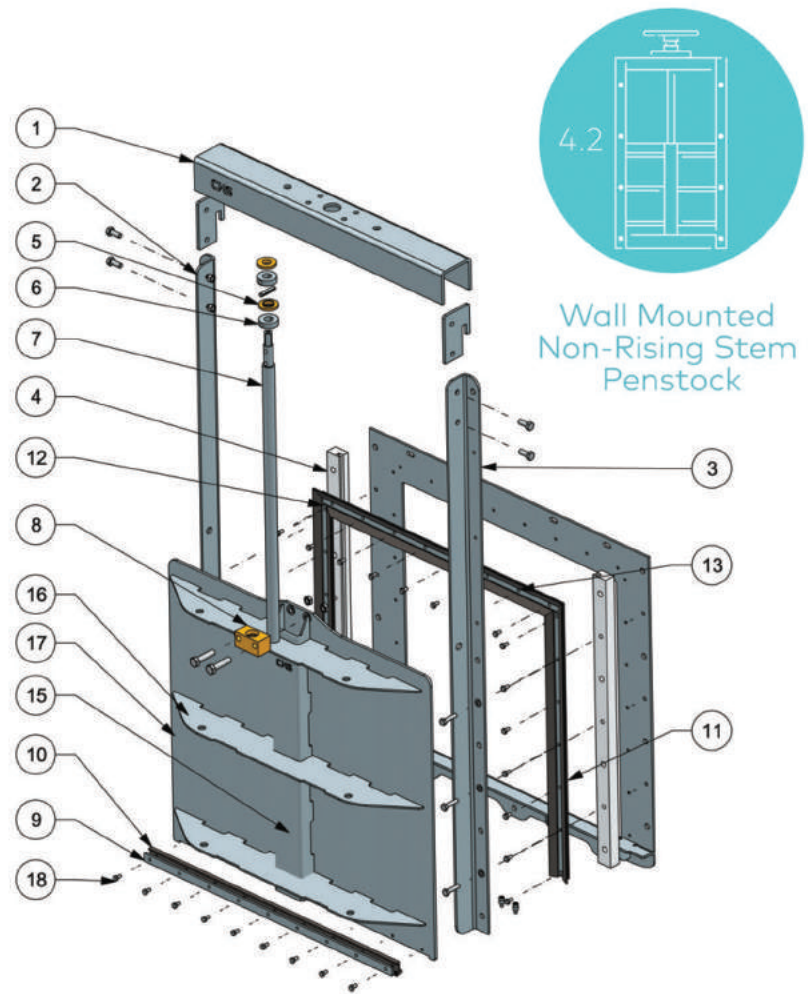

ITEM	DESCRIPTION	MATERIAL (STANDARD)
1	Yoke	Stainless Steel 304 or 316
2	Left Frame Guide	Stainless Steel 304 or 316
3	Right Frame Guide	Stainless Steel 304 or 316
4	Side Slider	High Molecular Weight Polyethylene (HMWPE)
5	Stem Bearing	Bronze
6	Stem Retaining Washer	Stainless Steel 304 or 316
7	Spindle Stem NRS	Stainless Steel 304 or 316
8	Stem Nut NRS	Bronze
9	Bottom Retainer Plate	Stainless Steel 304 or 316
10	Bottom L Gasket	EPDM
11	Damper Gasket Joint	EPDM
12	Lateral Retainer Plate	Stainless Steel 304 or 316
13	Top Retainer Plate	Stainless Steel 304 or 316
14	Body Frame	Stainless Steel 304 or 316
15	Gate Vertical Stiffener	Stainless Steel 304 or 316
16	Gate Horizontal Stiffener	Stainless Steel 304 or 316
17	Gate	Stainless Steel 304 or 316
18	Hex Bolt	Stainless Steel 304 or 316



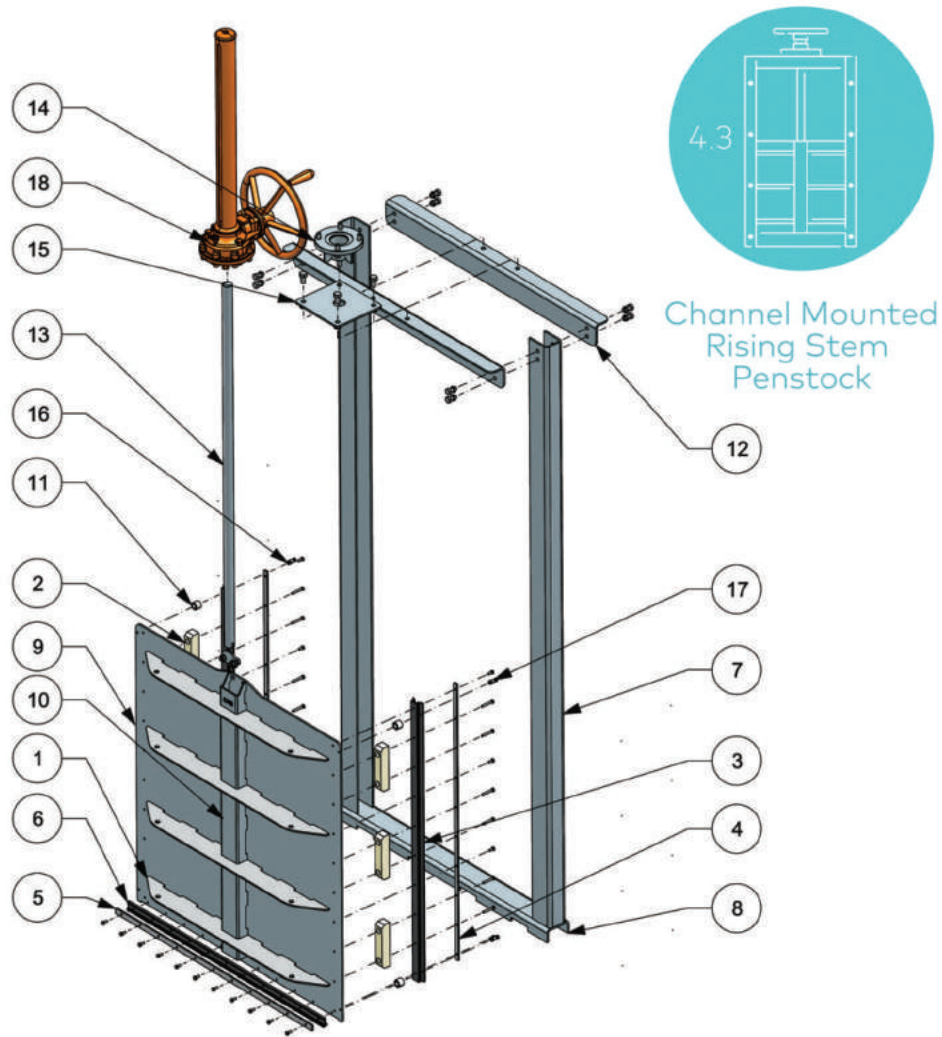

ITEM	DESCRIPTION	MATERIAL (STANDARD)
1	Gate Horizontal Stiffener	Stainless Steel 304 or 316
2	Face Slide	High Molecular Weight Polyethylene (HMWPE)
3	Damper Gasket	EPDM
4	Lateral Retainer Plate	Stainless Steel 304 or 316
5	Bottom Retainer Plate	Stainless Steel 304 or 316
6	Bottom L Gasket	EPDM
7	C Channel - Side	Stainless Steel 304 or 316
8	C Channel - Bottom	Stainless Steel 304 or 316
9	Gate	Stainless Steel 304 or 316
10	Gate Vertical Stiffener	Stainless Steel 304 or 316
11	Gate Bearing	High Molecular Weight Polyethylene (HMWPE)
12	Yoke	Stainless Steel 304 or 316
13	Spindle Stem RS	Stainless Steel 304 or 316
14	ISO Top Flange	Stainless Steel 304 or 316
15	Yoke Base Plate	Stainless Steel 304 or 316
16	Hex Bolt	Stainless Steel 304 or 316
17	Bearing Bush	Stainless Steel 304 or 316
18	Bevel Gear	Ductile Iron

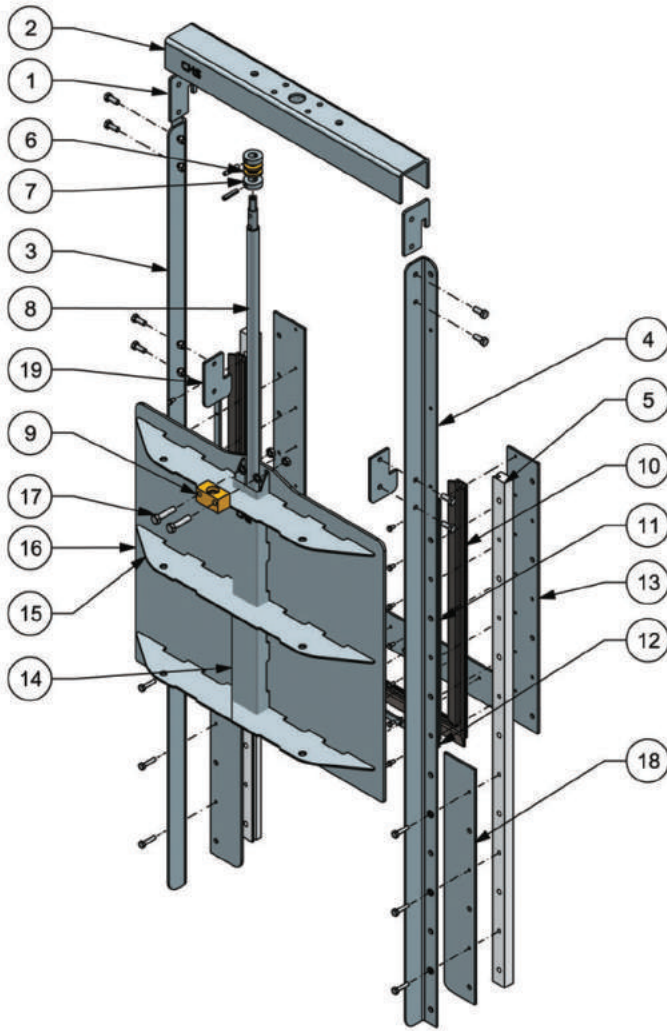

Non-Rising  
Stem  
Weir Gate

ITEM	DESCRIPTION	MATERIAL (STANDARD)
1	Yoke Stiffener	Stainless Steel 304 or 316
2	Yoke	Stainless Steel 304 or 316
3	Left Frame Guide	Stainless Steel 304 or 316
4	Right Frame Guide	Stainless Steel 304 or 316
5	Side Slider	High Molecular Weight Polyethylene (HMWPE)
6	Stem Bearing	Bronze
7	Stem Retaining Washer	Stainless Steel 304 or 316
8	Spindle Stem NRS	Stainless Steel 304 or 316
9	Stem Nut NRS	Bronze
10	Damper Gasket Joint	EPDM
11	Lateral Retainer Plate	Stainless Steel 304 or 316
12	Top Retainer Plate	Stainless Steel 304 or 316
13	Body Frame	Stainless Steel 304 or 316
14	Gate Vertical Stiffener	Stainless Steel 304 or 316
15	Gate Horizontal Stiffener	Stainless Steel 304 or 316
16	Gate	Stainless Steel 304 or 316
17	Hex Bolt	Stainless Steel 304 or 316
18	Body Frame Leg	Stainless Steel 304 or 316
19	Stop Plate	Stainless Steel 304 or 316



## 4.0 LECOTECH PENSTOCK ACCESSORIES



Headstock Floor Stand or Pedestal



Extension Spindle and Spindle Guide



Floor Stand/ Headstock Mounting Bracket



Muff Coupler



Spindle Cover

## Headstock Floor Stand or Pedestal 4.1



Inclined Headstock



Manual with Handwheel



Manual with Gear Box



Electric Actuator



Pneumatic/ Hydraulic

All actuators can be yoke or pedestal mounted, below are some examples of the most common types:

- |   |   |
|---|---|
| (A) Handwheel on inclined floor stand.          | (E) Hydraulic or pneumatic actuator.                                      |
| (B) Handwheel on straight floor stand.          | (F) Square nut. (BS 5163-2, DIN 3223 or 2" sqr)(Only for Non-Rising stem) |
| (C) Bevel Gear operator on headstock/ pedestal. | (G) Yoke mounted handwheel.   |
| (D) Electric actuator on straight floor stand.  |   |

As default, these headstocks are fabricated from mild steel with epoxy coating but are also available in hot dip galvanized mild steel, stainless steel, and cast iron upon request.



## 4.2 Extension Spindle and Spindle Guide

In most cases, the operating floor level is located substantially higher than the opening. In order to be able to operate the gate, stem extensions are necessary. Stem guides are used to limit the "supported" length of the stem extension in order to avoid any buckling failure.

The stem guide has a HWMPE guide to reduce friction between the guide and the extension spindle.

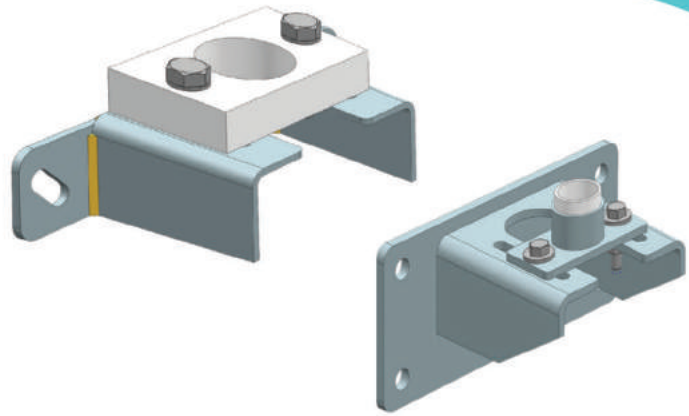

## Headstock 4.3 Mounting Bracket

In the event where the site structural works does not provide for headstock installation, a floor stand/ headstock mounting bracket can be used to provide support the headstock. **LECOTECH** standard headstock mounting bracket are fabricated using mild steel, complete with standard epoxy coating finishing.

## 4.4 Muff Coupler

As standard, **LECOTECH** muff coupler are manufactured in SUS304 / SUS316 for joining straight lengths of spindle in-line. For use with axial and torsion loads (rising and non-rising spindle application).



Ductile iron muff coupler are available upon request.

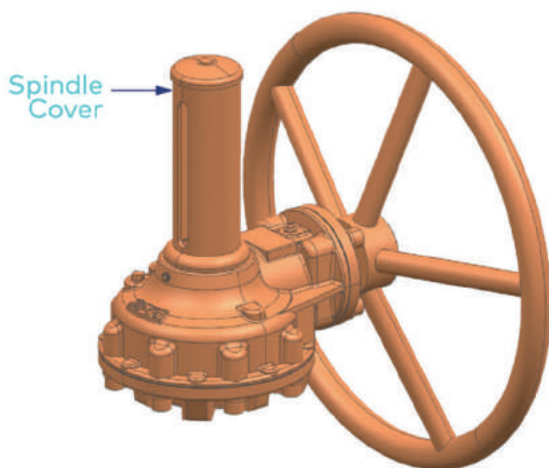

## Spindle Cover 4.5

It is used for rising stem penstock. It helps to protect the spindle when the spindle position protruded from the top of operation equipment like handwheel, gearbox, actuator and etc. It is useful, especially the penstock use in outdoor application. The material can be select from Mild Steel, Acrylic and Polycarbonate.

## 4.6 Installation, Operation and Maintenance

This section briefly describes the installation, operation and maintenance of WM/CM/WG penstocks. For more detailed information please refer to the "WM/CM/WG IOM Manual"

### Installation:

WM/CM/WG penstocks are installed by means of Anchor Bolts. Depending on the size and working conditions they shall be either of the mechanical or chemical type (see table below). In order to avoid leakage between the concrete wall and the frame, We recommends the use of construction sealant equivalent to Sikaflex 11FC sealant (200ml per meter of opening perimeter).

The minimum concrete strength shall be 20.7 MPa. The tolerance of the concrete construction shall be in accordance to DIN 18202. For detailed information about type, size and quantity of the required anchor bolts at the installation, please refer to the notes on the "General Arrangement Drawing".

### Maintenance and Operation:

The WM/CM/WG penstocks need practically no maintenance. The stem shall be kept lubricated and seals shall be replaced if damaged. The WM/CM/WG penstock is closed by applying a clockwise rotation. Applying too much force when closing the gate may cause damage to the stem

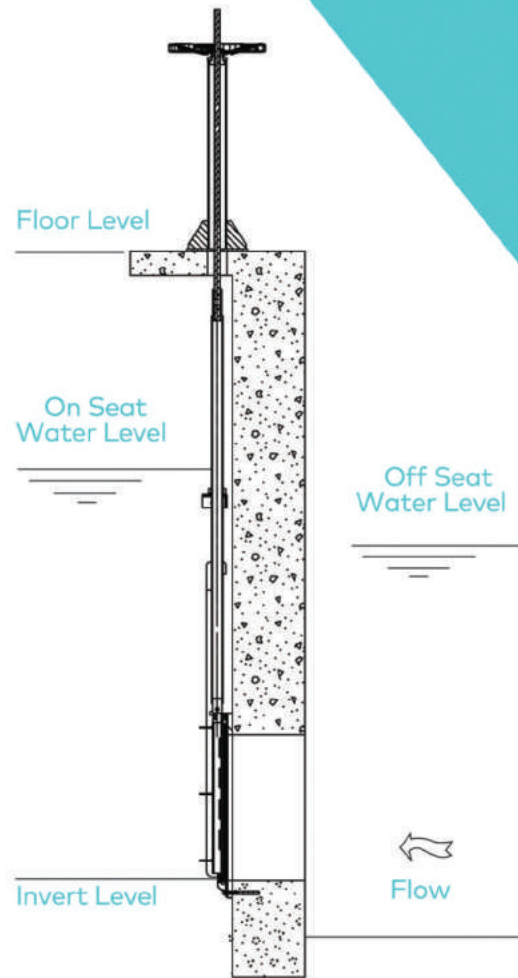
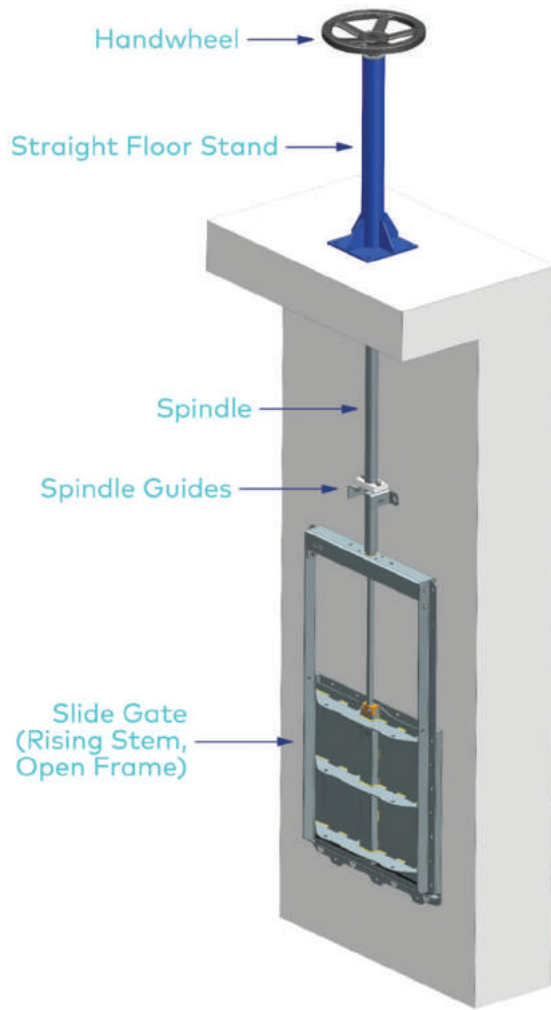

Seating / Unseating Design Head:		
Size	Water Pressure	Standard Mounting Type
<b>Bi-Directional (Standard Range)</b> 150mm x 150mm - 1200mm x 1200mm	Seating and Un-Seating (Bi-Directional)	Wall Mount: • Stud Type Mechanical Anchor Bolts
<b>Bi-Directional</b> 1300mm x 1300mm - 4000mm x 4000mm	Seating and Un-Seating (Bi-Directional)	Wall mount + chemical anchor bolt Optional embedded in concrete.



# PENSTOCK INQUIRIES FORM

Company:  Date:  /  /

Mobile:  Tel:

Email:  Name:

## PENSTOCK APRETURE SIZE

Units in:  mm  
 cm

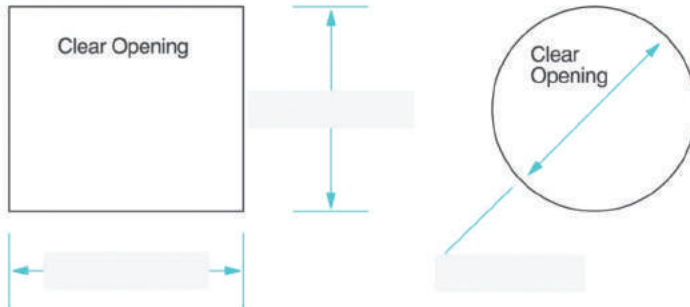

Qty:

Qty:

## HEADSTOCK OPTION

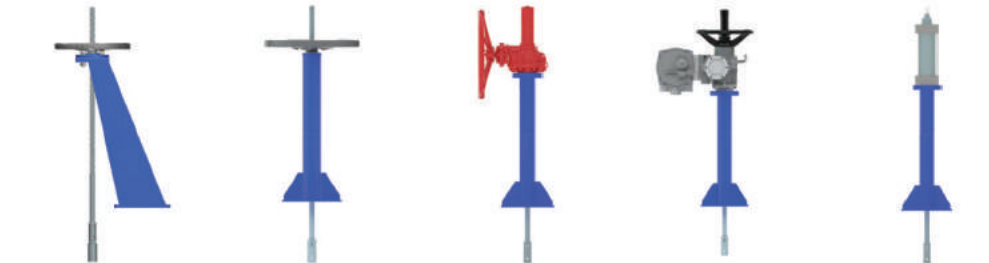

Inclined Headstock

Manual with Handwheel

Manual with Gear Box

Electric Actuator

Pneumatic

Hydraulic

## MATERIAL

Stainless Steel SS304

Stainless Steel SS316

Cast Iron

Ductile Iron

Carbon Steel

## SEALING

4 Sides Sealed

3 Sides Sealed

## CLOSING

Downward Closing

Upward Closing

## SPINDLE

Rising Spindle

Non-rising Spindle

## MATERIAL

Concrete Wall

Wall Timble

Channel / Drain

Other, Pls Specify

## HEADSTOCK MOUNTING

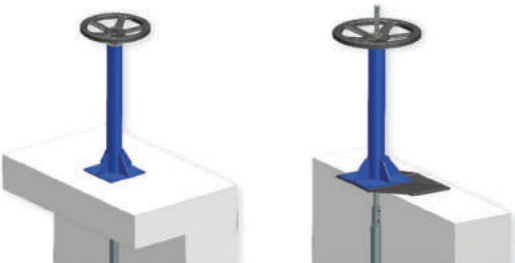

Headstock Mounted on Slab

Headstock Mounted Z-type Bracket

## PENSTOCK DESIGN REQUIREMENT

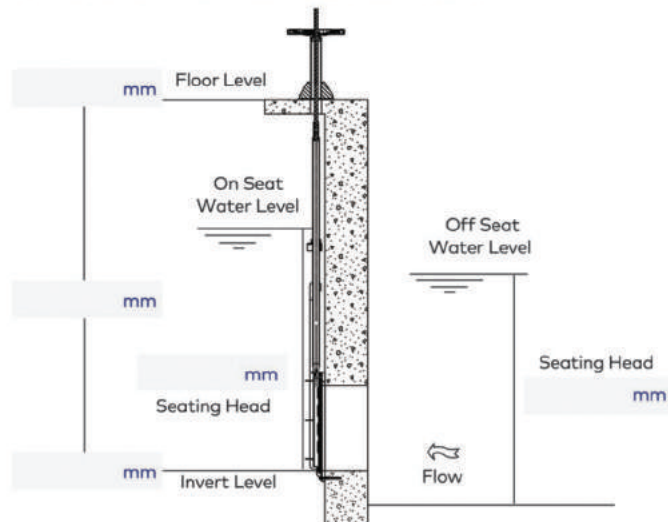



**SALES & MARKETING :**

**LECOTECH ENGINEERING SDN. BHD.**

**Office :**

No. 38, Jln 18/4, 46000 Petaling Jaya, Selangor

**Factory :**

No. 18, Jln Sungai Jeluh 32/189, Bukit Naga Industrial Park,  
Seksyen 32, 40460 Shah Alam, Selangor

**T** +6011-2605 2600

**T** +6012-999 3335

**E** [lee.lecotech@gmail.com](mailto:lee.lecotech@gmail.com)

**F** +603-7781 6288